

## 1.5A 280kHz Boost Regulators AMC3202DMF

### DESCRIPTIONS :

The AMC3202 is a 280kHz switching regulator with a high efficiency, 1.5A integrated switch. The part operates over a wide input voltage range, from 2.7V to 30V. The AMC3202 utilizes current mode architecture, which allows excellent load and line regulation, as well as a practical means for limiting current. Combining high frequency operation with a highly integrated regulator circuit results in an extremely compact power supply solution.

Build-in thermal protection to prevent the chip over heat damage.

### FEATURES

- Integrated Power Switch: 1.5A Guaranteed.
- Wide Input Range: 2.7V to 30V.
- 40V Power Switch Input Voltage.
- High Frequency Allows for Small Components.
- Minimum External Components.
- Built in Over Current Protection.

### APPLICATION

- TFT-LCD Power Management
- LCD Monitor/TV LED Backlight Driver

### Outline Drawing:

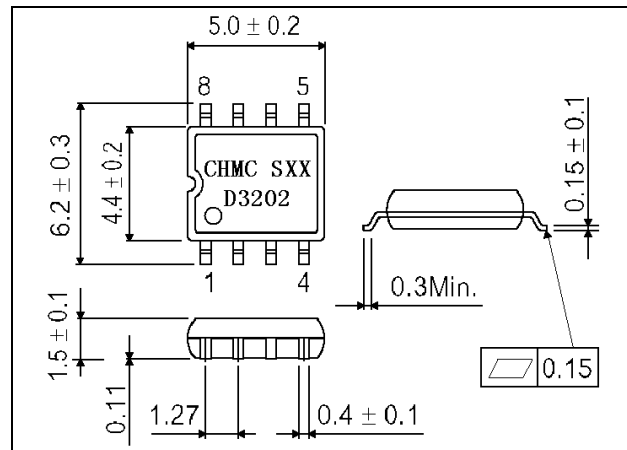

**BLOCK DIAGRAM AND PIN CONFIGURATION**

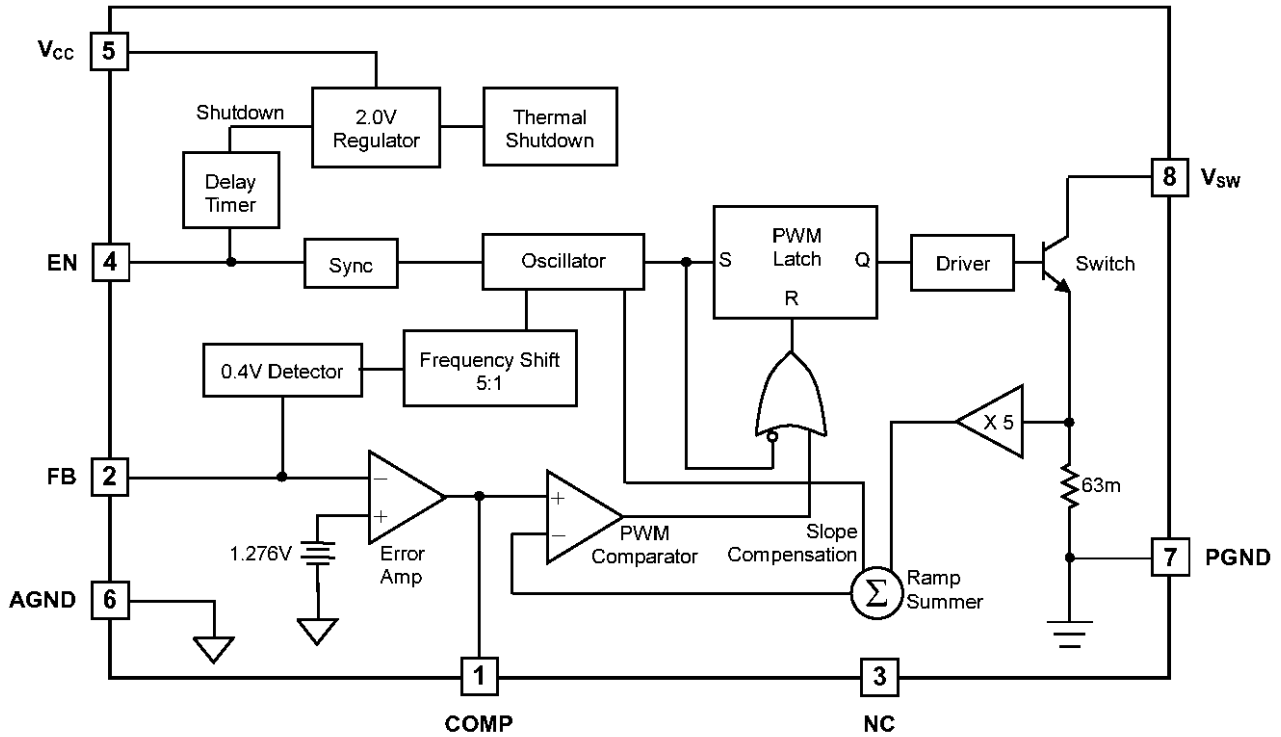

**PIN DESCRIPTION**

Pin No.	Pin Name	Pin Function
1	COMP	Loop compensation pin. This pin is the output of the error amplifier and is used for loop compensation. Loop compensation can be implemented by a simple RC network.
2	FB	Feedback pin. Sense the output voltage and referenced to 1.276V. When the voltage at this pin falls below 0.4V, chip switching-frequency reduces to a much lower frequency.
3	NC	No connection. Keep floating.
4	EN	Enable pin. A TTL low will shut down the chip and high enable the chip. This pin may also be used to synchronize the part to nearly twice the base frequency. If synchronization is not used, this pin should be either tied high or left floating for normal operation.
5	V <sub>CC</sub>	Input power supply pin. Supply power to the IC and should have a bypass capacitor connected to AGND
6	AGND	Analog ground. Provide a clean ground for the controller circuitry and should not be in the path of large currents. This pin is connected to the IC substrate.
7	PGND	Power ground. This pin is the ground connection for the emitter of the power switching transistor. Connection to a good ground plane is essential.
8	V <sub>sw</sub>	High current switch pin. Connect to the collector of the internal power switch. The open voltage across the power switch can be as high as 40V. To minimize radiation, use a trace as short as practical.

**ABSOLUTE MAXIMUM RATINGS** (Ta=25°C)

Characteristic	Symbol	Value	Unit
Input Voltage	Vcc	30	V
Switch Input Voltage,	Vsw	40	V
Maximum Operating Junction Temperature	Tj	150	°C
Storage Temperature	Tstg	-65 ~ +150	°C
Lead Temperature(Soldering,10seconds)		260	°C

\* Exceeding these ratings could cause damage to the device. All voltages are with respect to Ground. Currents are positive into, negative out of the specified terminal.

**ELECTRICAL CHARACTERISTICS**

(Unless otherwise noted: 2.7V<Vcc<30V,Ta=25 )

Characteristics	Test conditions	Min	Typ	Max	Unit
FB Reference Voltage	V <sub>COMP</sub> tied to FB;Measure at FB	1.246	1.276	1.300	V
FB Input Current	FB=V <sub>REF</sub>	-1.0	0.1	1.0	μA
FB Reference Voltage Line Regulation	V <sub>COMP</sub> =FB, 2.7V<Vcc<30V		0.01	0.03	%/V
Error Amp Transconductance	I <sub>V<sub>COMP</sub></sub> =±25μA	300	550	800	uMho
Error Amp Gain	*	200	500		V/V
V <sub>COMP</sub> Source Current	FB=1.0V, V <sub>COMP</sub> =1.25V	25	50	90	μA
V <sub>COMP</sub> Sink Current	FB=1.5V, V <sub>COMP</sub> =1.25V	200	625	1500	μA
V <sub>COMP</sub> High Clamp Voltage	FB=1.0V, V <sub>COMP</sub> sources 25μA	1.5	1.7	1.9	V
V <sub>COMP</sub> Low Clamp Voltage	FB=1.5V, V <sub>COMP</sub> sinks 25μA	0.25	0.50	0.65	V
V <sub>COMP</sub> Threshold	Reduce V <sub>COMP</sub> from 1.5V until switching stops	0.75	1.05	1.30	V
Base Operating Frequency	FB=1V	230	280	310	kHZ
Reduced Operating Frequency	FB=0V	30	52	120	kHZ
Maximim Duty Cycle		90	94		%
FB Frequency Shift Threshold	Frequency drops to reduced operating frequency	0.36	0.40	0.44	V
Synchronization range		320		500	kHZ
Synchronization Pulse Transition Threshold	Rise time=20ns	2.5			V
EN Bias Current	EN=0V EN=3.0V	-15	-3.0 3.0	8.0	μA
Shutdown Threshold		0.50	0.85	1.20	V
Shutdown Delay	2.7V≤Vcc≤12V 12V≤Vcc≤30V	12 12	80 36	350 200	μS

Switch Saturation Voltage	$I_{SWITCH}=1.5A$ $I_{SWITCH}=1.0A$ $I_{SWITCH}=10mA$		0.8 0.75 0.09	1.5 0.45	V
Switch Current Limit	50% duty cycle 80% duty cycle	1.5 1.4	1.8 1.6	2.3 2.1	A
Minimum Pulse Width	FB=0V, I <sub>sw</sub> =1.0A	100	250	300	nS
Switch Leakage	V <sub>sw</sub> =40V, V <sub>cc</sub> =0V		2.0	100	μA
ΔI <sub>cc</sub> /ΔI <sub>vsw</sub>	2.7V ≤ V <sub>cc</sub> ≤ 12V, 10mA ≤ I <sub>sw</sub> ≤ 1.0A 12V ≤ V <sub>cc</sub> ≤ 30V, 10mA ≤ I <sub>sw</sub> ≤ 1.0A 2.7V ≤ V <sub>cc</sub> ≤ 12V, 10mA ≤ I <sub>sw</sub> ≤ 1.5A 12V ≤ V <sub>cc</sub> ≤ 30V, 10mA ≤ I <sub>sw</sub> ≤ 1.5A		10 - 17 -	30 100 30 100	mA/A
Operating Current	I <sub>sw</sub> =0		5.5	8.0	mA
Shutdown Mode Current	V <sub>COMP</sub> <0.8V, EN=0V, 2.7V ≤ V <sub>cc</sub> ≤ 12V V <sub>COMP</sub> <0.8V, EN=0V, 12V ≤ V <sub>cc</sub> ≤ 30V		12	60 100	μA
Minimum Operation Input Voltage	V <sub>sw</sub> switching, maximum I <sub>sw</sub> =10mA		2.45	2.70	V
Thermal shutdown		150	180	210	
Thermal Hysteresis			25		

\* Guaranteed by design, not 100% tested in production.

### APPLICATION CIRCUIT

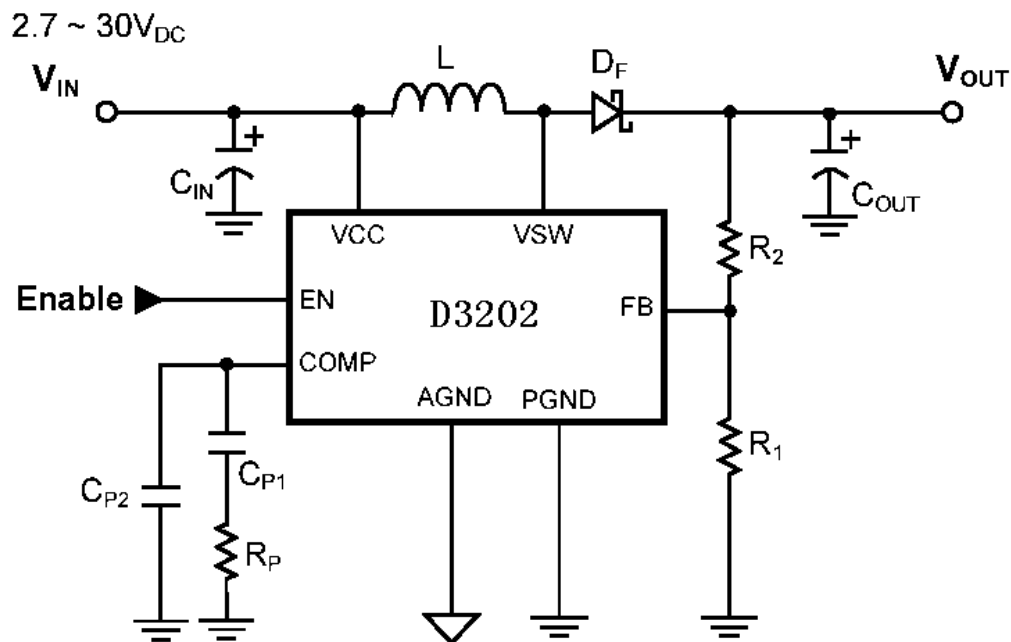

**APPLICATION SUMMARY**

The AMC3202 incorporates a current mode control scheme, in which the duty cycle of the switch is directly controlled by switch current rather than by output voltage. The output of the oscillator turns on the power switch at a frequency of 280kHz as shown in the block diagram. The power switch is turned off by the output of the PWM comparator.

A TTL low voltage will shut down the chip and high voltage enable the chip through EN pin. This pin may also be used to synchronize the part to nearly twice the base oscillator frequency. In order to synchronize to a higher frequency, a positive transition turns on the power switch before the output of the oscillator goes high, thereby resetting the oscillator. The synchronization operation allows multiple power supplies to operate at the same frequency. If synchronization is not used, this pin should be either tied high or left floating for normal operation.

Component Selection:

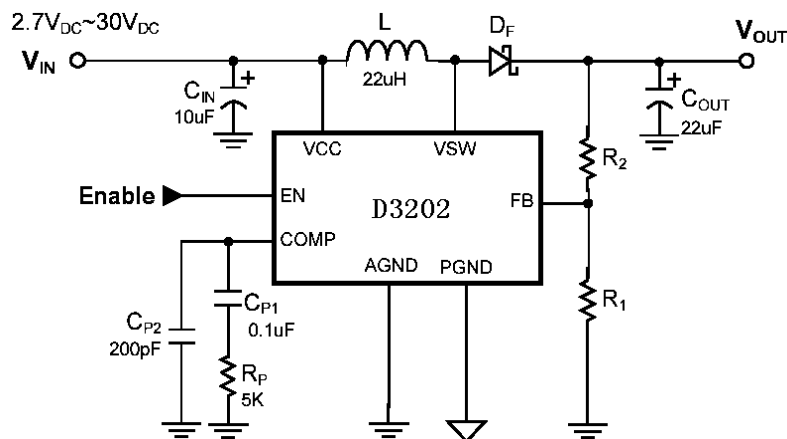

The AMC3202 develops a 1.276V reference from the FB pin to ground. Output voltage is set by connecting the FB pin to an output resistor divider and the maximum output voltage is determined by the VSW pin maximum voltage minus the output diode forward voltage. Referring to typical application circuit, the output voltage is set by the below formula(1):

$$V_{OUT} = 1.276V \left( 1 + \frac{R_2}{R_1} \right) \quad 2.7V \leq V_{OUT} \leq 40V - V_F \tag{1}$$

where,  $V_F$  is the output diode  $D_F$  forward voltage.

When choosing the inductor, one must consider factors such as peak current, core and ferrite material, output voltage ripple, EMI, temperature range, physical size, and cost.

Lower values are chosen to reduce physical size of the inductor, and higher values reduce ripple voltage and core loss. In continuous conduction mode, the peak inductor current is equal to average current plus half of the ripple current, which should not cause inductor saturation. Based on the tolerance of the ripple current in the circuits, the following formula (2) can be referenced:

$$I_{Ripple} = \frac{V_{IN}(V_{OUT} - V_{IN})}{fLV_{OUT}} \quad \text{where, } f = 280\text{kHz.} \quad (2)$$

In Boost circuits, the inductor becomes part of the input filter. In continuous mode, the input current waveform is triangular and does not contain a large pulsed current. This reduces the requirements imposed on the input capacitor selection. Capacitors in the range of 10uF to 100uF with an ESR less than 0.3 $\Omega$ , work well up to full 1.5A switch current.

The  $V_{IN}$  ripple is determined by the product of the inductor current ripple and the ESR of input capacitor, and the  $V_{OUT}$  ripple comes from two major sources, namely ESR of output capacitor and the charging/discharging of the output capacitor. Ceramic capacitors have the lowest ESR, but too low ESR may cause loop stability problems. Aluminum Electrolytic capacitors exhibit the highest ESR, resulting in the poorest AC response. One option is to parallel a ceramic capacitor with an Aluminum Electrolytic capacitor.

The goal of frequency compensation is to achieve desirable transient response and DC regulation while ensuring the stability of the system. A typical compensation network, as shown in the typical application circuit, provides a frequency response of two poles and one zero. The loop frequency compensation is performed on the output of the error amplifier (COMP pin) with a series RC network. The main pole is formed by the series capacitor and the output impedance of the error amplifier. The series resistor creates a zero, which improves loop stability and transient response. A second capacitor, is sometimes used to reduce the switching frequency ripple on the COMP pin.

$$f_{P1} = \frac{1}{2\pi C_{P1} R_O} \quad \text{where, } R_O = \text{error amplifier output resistance;}$$

$$f_{Z1} = \frac{1}{2\pi C_{P1} R_P}$$

$$f_{P2} = \frac{1}{2\pi C_{P2} R_P}$$